

**BATTERY STRAPPING TOOL FOR PLASTIC STRAP P.P.— P.E.T.
DIGITAL CONTROL — FLAT AND ROUND SURFACE**

TECHNICAL DATA / APPLICATIONS :

Compact, easy to use and versatile battery strapping tool equipped by new adjustment keyboard. Reliable to be used in industrial medium / light applications. Available in two models LT (low tension) and POWER (high tension) with different strap tension values. All the tools are produced standard for strap size 16mm (5/8") and are completed with 10mm(3/8"), 13mm(1/2"), 19mm(3/4") strap guides included into the box. One battery is provided with the tool; the battery recharger is an optional.

Package type	Flat (minimun 120mm—5") Round surface (min.diam. 700mm —28")
Strap quality	PP / PET
Strap Width	From 10mm up to 19mm (3/8"- 3/4")
Strap thickness	From 0,5mm up to 1.05mm (0.019"- 0.041")
Max. Tension	2000N
Max. Tension speed	Around 9 mt/min
Joint type	Friction weld seal
Weight	Around 4,3Kg (battery included)
Order code Digit LT	122.990.810

- * EASY TO USE
- * NEW DESIGN
- * LIGHT AND COMPACT
- * ERGONOMIC HANDLE
- * NEW ELECTRONIC EQUIPMENTS

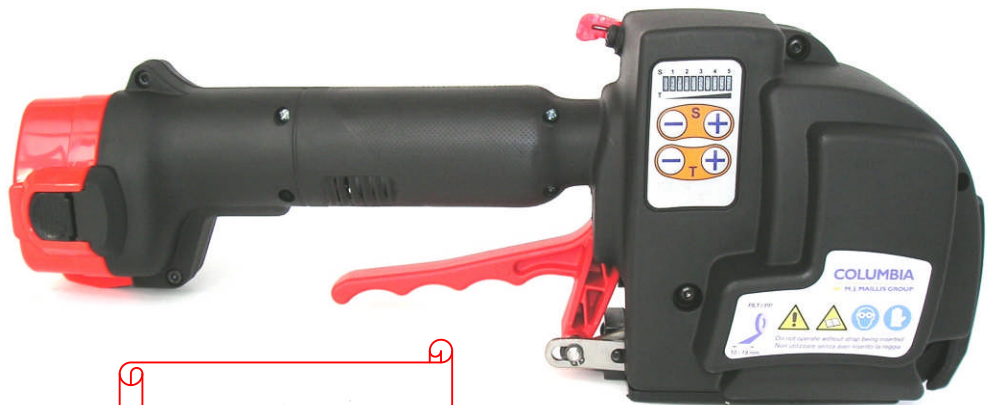

NEW

DIGITAL KEYBOARD TO ADJUST TENSION AND SEALING TIME



BATTERY STRAPPING TOOL FOR PLASTIC STRAP P.P.— P.E.T. DIGITAL CONTROL — FLAT AND ROUND SURFACE

TECHNICAL DATA / APPLICATIONS :

Compact, easy to use and versatile battery strapping tool equipped by new adjustment keyboard. Reliable to be used in industrial medium / light applications. Available in two models LT (low tension) and HT (high tension) with different strap tension values. All the tools are produced standard for strap size 16mm (5/8") and are completed with 10mm(3/8"), 13mm(1/2"), 19mm(3/4") strap guides included into the box. One battery is provided with the tool; the battery recharger is an optional.

Package type	Flat (minimun 120mm—5") Round surface (min.diam. 700mm –28")
Strap quality	PP / PET
Strap Width	From 10mm up to 19mm (3/8" - 3/4")
Strap thickness	From 0,5mm up to 1.05mm (0.019" - 0.041")
Max. Tension	3300N
Max. Tension speed	Around 9 mt/min
Joint type	Friction weld seal
Weight	Around 4,5 Kg (battery included)
Order code Digit HT	121.990.810

- * EASY TO USE
- * NEW DESIGN
- * LIGHT AND COMPACT
- * ERGONOMIC HANDLE
- * NEW ELECTRONIC EQUIPMENTS



DIGITAL KEYBOARD TO ADJUST TENSION AND SEALING TIME



- EASY AND FAST ADJUSTMENTS

GUIDESTRAP ADJUSTMENT

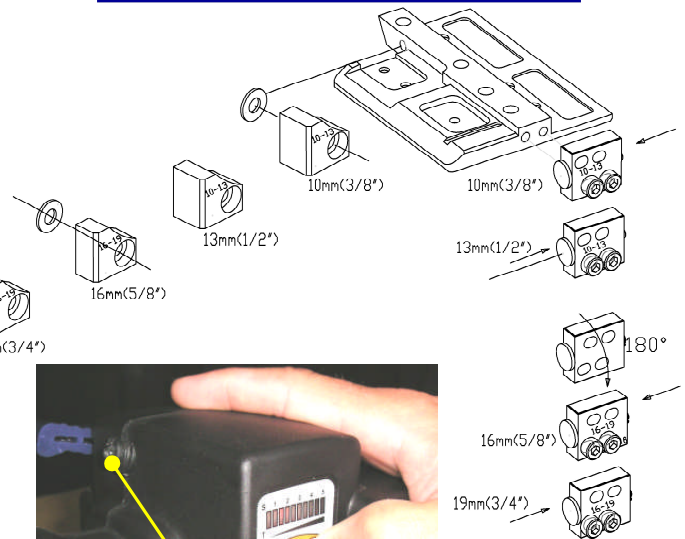
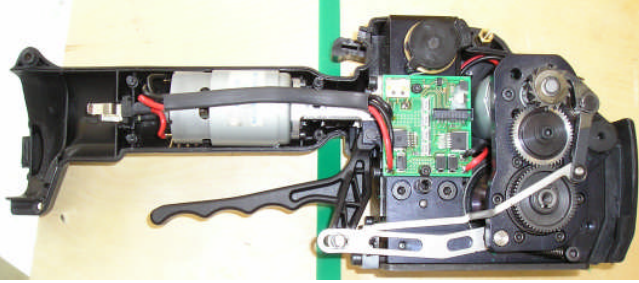

TURN THIS SCREW TO ADJUST THE GAP BETWEEN THE FEEDWHEEL AND LOCK STRAP PLATE



FLASHING LED

LED SCALE DISPLAY FOR BOTH ADJUSTMENTS

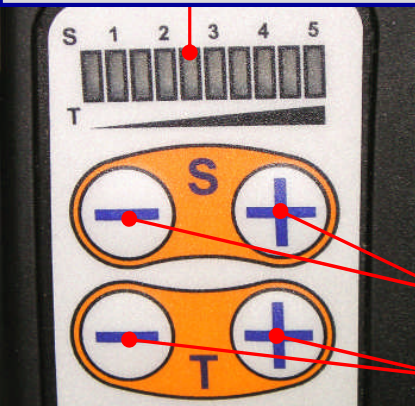

TO ADJUST THE PARAMETERS WITH KEYBOARD:

- 1) THE GREEN LED ON TOOL SHOULD BE FLASHING (DO A TENSION CYCLE TO ACTIVE IT)
- 2) HOLD PUSHED FOR 3-4 SECONDS THE BUTTON **S** + **_** UNTILL THE LED SCALE IS LIGHTED
- 3) PUSH THE SINGLE BUTTON – OR + TO ADJUST THE TENSION FORCE OR THE SEALING TIME (YOU WILL SEE THE RESULT ON LED SCALE)
- 4) TO RECORD THE NEW PARAMETERS YOU HAVE TO WAIT THAT THE LED SCALE WILL SWITH OFF (DON'T LEAVE THE BATTERY)

SEALING TIME ADJUSTMENT PUSH-BUTTONS

TENSION FORCE ADJUSTMENT PUSH-BUTTONS

PUSH TO TENSION THE STRAP – ONLY ONE LEVER TO USE – TURN TO WELD THE STRAP

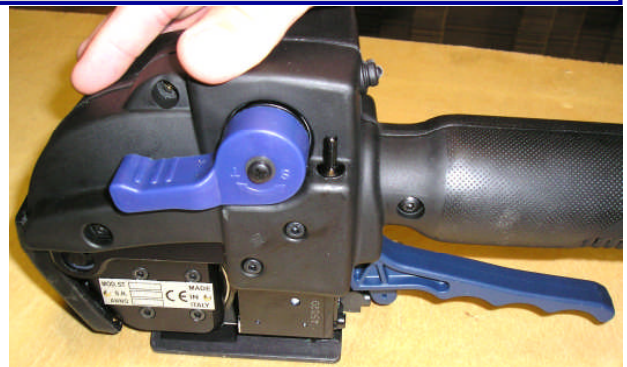

- TYPICAL APPLICATIONS

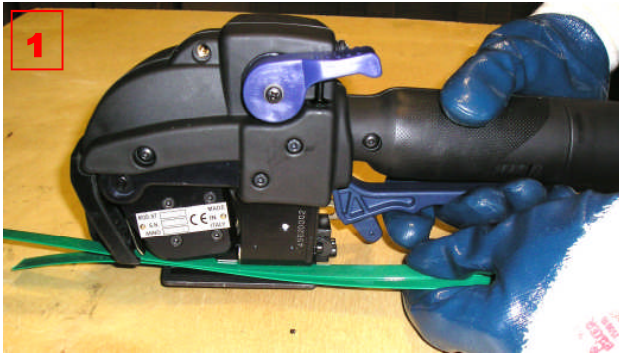

1
INSERT THE STRAP

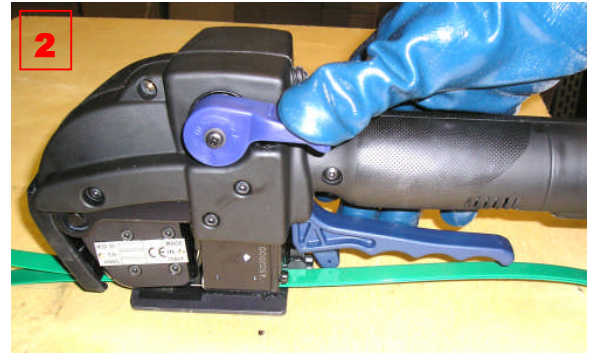

2
TENSION PHASE

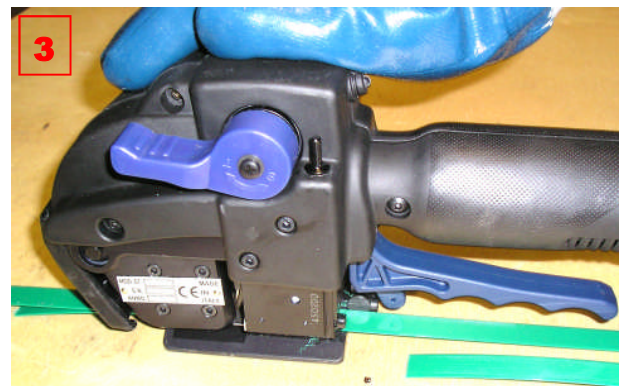

3
SEALING AND CUTTING PHASE

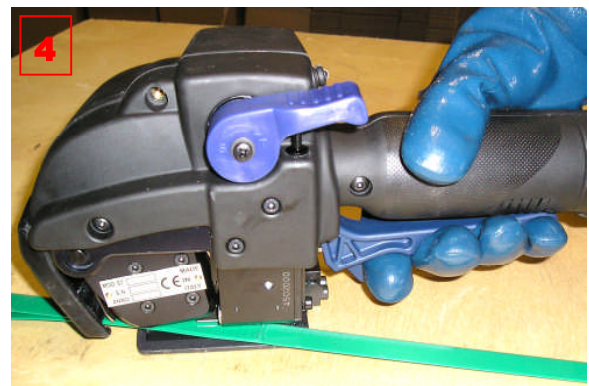

4
WAIT UNTILL GREEN LED IS FLASHING,
TURN BACK THE SEALING LEVER AND
OPEN THE TOOL

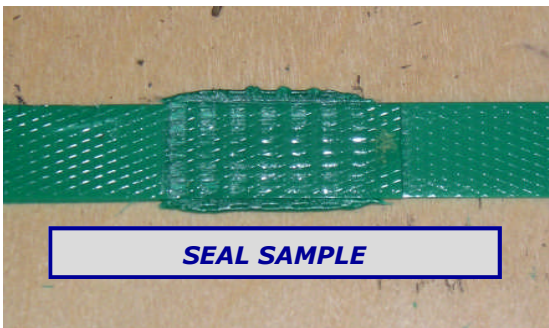

SEAL SAMPLE

- * MECHANICAL INDUSTRIES
- * PROFILES, PIPES, EXTRUDES
- * PAPER AND CARTON INDUSTRIES
- * BRICKS
- * WOOD
- * ALLUMINUM FOUNDRY

ACCESSORIES

- **BATTERY RECHARGER MAKITA (FAST CHARGE) CODE 521.002.650**
- **BATTERY RECHARGER MAKITA (SLOW CHARGE) CODE 521.002.610**
- **SUPPLEMENTAR BATTERY 2.0 A/h 12V NI-CD (RED) CODE 521.002.600**
- **SUPPLEMENTAR BATTERY 2.6 A/h 12V NI-MH (BLACK) CODE 521.002.620**
- **BALANCER 3-6KG CODE 605.080.080**
- **BATTERY DISCHARGER CODE 610.100.730**

OPTIONALS

- **SUSPENSION BRACKET KIT FOR VERTICAL POSITION CODE 281.018.600**
- **SUSPENSION BRACKET KIT FOR LATERAL POSITION CODE 281.018.700**

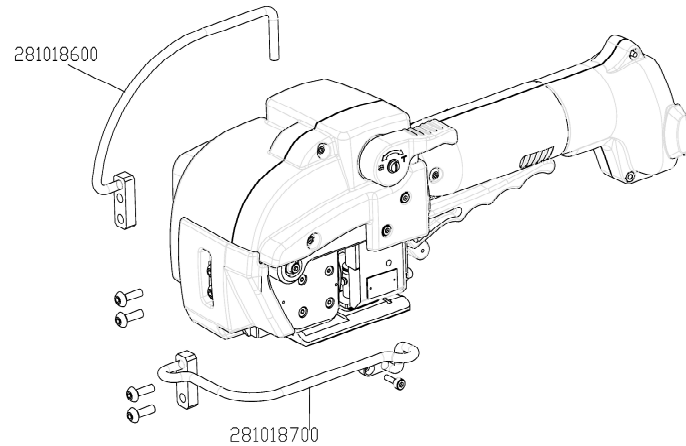

ALL SPECIFICATIONS ARE CORRECT AT TIME OF PRINT, ARE FOR GUIDANCE PURPOSE ONLY AND SUBJECT TO CHANGE WITHOUT PRIOR NOTICE –09/04

COLUMBIA S.r.l. Packing Systems & Materials -Via Della Repubblica, 44 – SOLARO (MI) – ITALY

TEL. +39.02.96790381 – FAX +39.02.96790397 – columbiatools@columbiatools.net—www.columbiatools.it